



Gaasiküttega õhupuhurite ja tarvikute hinnakiri

Gas Air Heaters and accessories pricelist

2022



Gasterm Eesti OÜ

www.gasterm.ee

+372 6150050

Tatari 21A/1,

info@gasterm.ee

Tallinn 10116

CLOE

ERP 
Energy related product
2021



**New Ultracondens® gas heater
with atmospheric burner and condensing exchanger**

Gasterm Gas Air Heater - CLOE serie is an ultracondens gas heater which has the best performances of the market. With its high efficiency of 104% at full power and its low NOx emissions, the CLOE complies with the new ERP2021 and allows significant energy savings and ensure heating confort into the building.

TYPICAL APPLICATION



Industries



Supermarkets



Sport facilities



Warehouses



Workshops



Greenhouses

Condensing Gas Air Heater CLOE

CLOE Condensing Gas Heater is running with natural gas (G20/G25) or propane gas (G31). The range includes 4 models from 15 to 63 kW

Product advantages	Customer benefits
104% efficiency at full power	Best performances of the market
2-stages gas valve (100% - 55%)	Good warm air distribution
Robust tubular heat exchanger	Reliable and long life service unit
Pilote wire system with display	Easy control system
Automatic security system	Safe use with maintenance support
Plastic flue pipes	Economic and easy to adjust

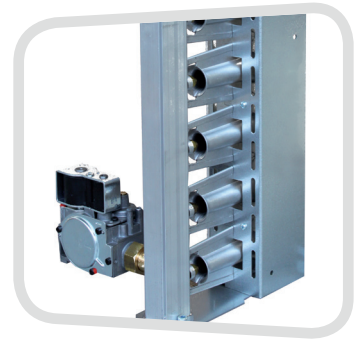

[Multi-jet gas burner]



[Condensing Heat exchanger]



[Pilote wire card]



[Axial fan]

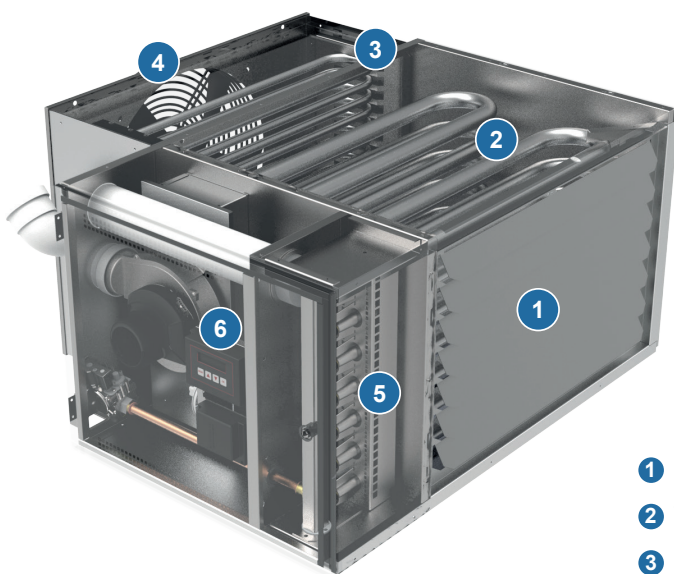

- 1 Louvers
- 2 Tubular Heat exchanger
- 3 Condensing heat exchanger
- 4 Axial fan
- 5 Atmospheric gas burner
- 6 Pilote wire card

CLOE



Performances

Modèles	CLOE25H	CLOE35H	CLOE45H	CLOE60H
Heat Input (kW)	26	34	51	61
Nominal Output (kW)	27	35	46	63
Thermal efficiency (%)	104	104	104	104
Minimal output (kW)	15	19	27	36
Thermal efficiency (%)	107	107	107	107
Air flow T 15°C (m3/h)	3 320	4 000	5 400	7 200
Seasonal efficiency above 88% - NOx lower than 70 mg/kWh				

Dimensions

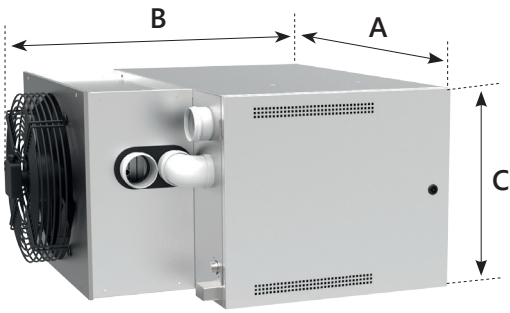

Models	CLOE25H	CLOE35H	CLOE45H	CLOE60H
A (mm)	1 060	1 060	1 060	1 060
B* (mm)	1 110	1 110	1 110	1 110
C (mm)	495	545	560	710
Gas (mm)	3/4"	3/4"	3/4"	3/4"
Fumes (mm)	80	80	80	80
Air (mm)	80	80	80	80
Weight (kg)	105	115	140	180

* From the front to back side of gas heater

Flue connection

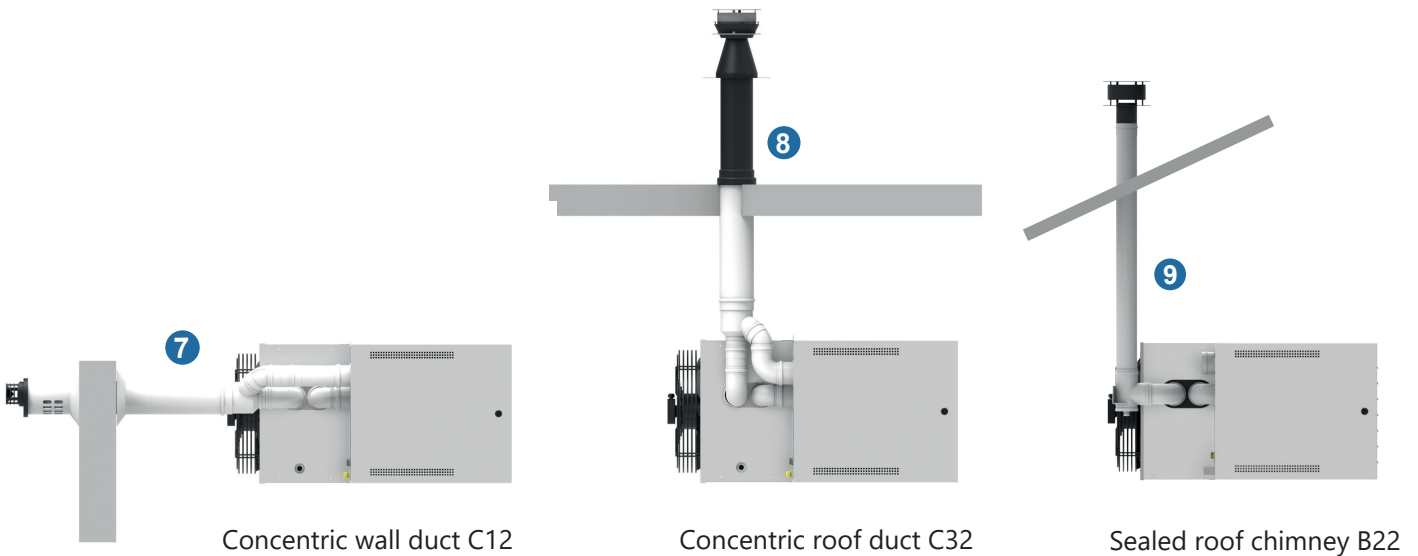

Prices

Models		CLOE25H	CLOE35H	CLOE45H	CLOE60H
Axial condensing gas heater		3 400 € CLOE25H	3 750 € CLOE35H	4 150 € CLOE45H	4 850 € CLOE60H
Gas connection	Natural gas kit 20 or 25 mBar	1		74 € KGN20	
	Natural gas kit 300 mBar	2		153 € KDGN55	
	Propane gas kit 1,5 Bar	3		168 € KDP55	
	Flexible gas connection	4		79 € FLEXIND3/4	
Fixation	Wall-mounted bracket	5		180 € COARX	
	Directional wall-mounted bracket	6		200 € CORARX	
	KRSJ kit for directional bracket			74 € KIPN	
Flue pipes	Concentric wall duct C12	7		205 € KC1280ARX	
	Concentric roof duct C32	8		340 € KC3280ARX	
	Sealed roof chimney B22	9		Consult us	
	Single extension 1 m			41 € LE80100R	
	Single extension 0,5 m			36 € LE80050R	
	Single elbow 45°			26 € CE8045R	
	Single elbow 90°			28 € CE8090R	
	Concentric extension 1 m			98 € LC80100R	
	Concentric extension 0,5 m			82 € LC80050R	
	Concentric elbow 45°			80 € CC8045R	
	Concentric elbow 90°			93 € CC8090R	
Regulation	Switch disconnecter	10		69 € BSAT4P	
	Thermostat + remote reset	11		106 € TFP1-ET85P2	
	Timer thermostat + remote reset	12		347 € TFP2TS (FRANCAIS) TFP2TSE (ENGLISH)	
	Timer thermostat with external sensor + remote reset			401 € TFP3TS (FRANCAIS) TFP3TSE (ENGLISH)	

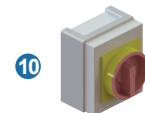
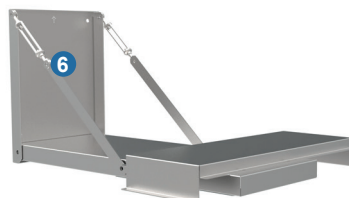
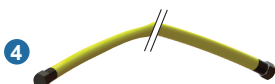
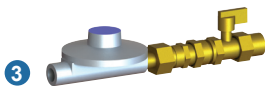
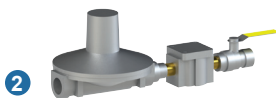
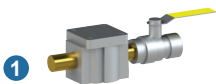



KARU

ERP 
Energy related product
2021



High efficiency gas heater
without condensing

Gasterm Gas Air Heater - KARU serie is an efficient non-condensing gas heater that complies with ERP2021. With its high efficiency up to 95% and its low NOx emissions, the KARU series gas heater allows significant energy savings without condensing. It ensures also heating confort into the building.

TYPICAL APPLICATION



Industries



Supermarkets



Sport facilities



Warehouses



Workshops



Greenhouses

Gas Air Heater

KARU Gas Air Heater is running with natural gas (G20/G25) or propane gas (G31). The range includes 5 models from 13 to 80 kW and 3 versions : axial and vertical for direct blowing (KARU-H, KARU-V) and centrifugal for fresh air supply or air duct systems (KARU-C).

Product advantages	Customer benefits
High efficiency up to 95%	Easy alternative to condensing heaters
2-stages gas valve (100% - 55%)	Good warm air distribution
Robust tubular heat exchanger	Reliable and long life service unit
Pilote wire system with display	Easy control system
Automatic security system	Safe use with maintenance support
Non-condensing heater	Easy to install and maintain

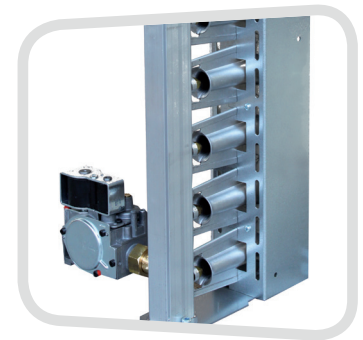

[Multi-jet gas burner]

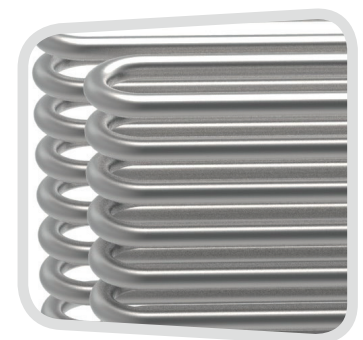

[Heat exchanger]



[Pilote wire card]



[Axial fan]

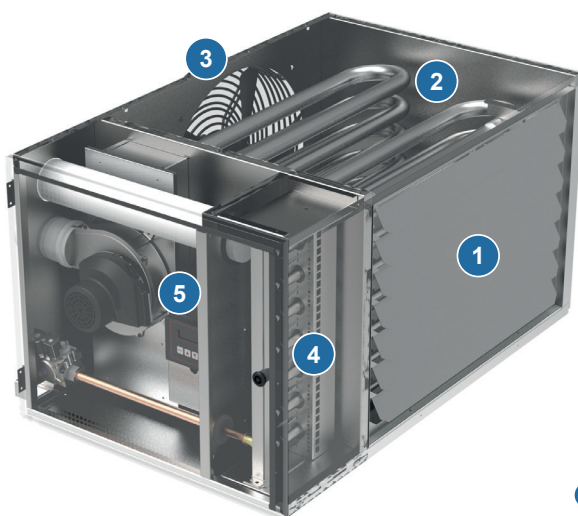

- ① Louvers
- ② Tubular Heat exchanger
- ③ Axial fan
- ④ Atmospheric gas burner
- ⑤ Pilote wire card



Performances

Modèles	KARU25H	KARU35H	KARU45H	KARU60H	KARU80H
Heat Input (kW)	26	36	46	61	80
Nominal Output (kW)	24	34	43	56	73
Thermal efficiency (%)	92	92	92	92	92
Minimal output (kW)	13	19	24	32	42
Thermal efficiency (%)	95	95	95	95	95
Air flow T 15°C (m3/h)	3 580	4 250	5 800	7 700	10 000

Seasonal efficiency above 78% - NOx lower than 70 mg/kWh

Dimensions

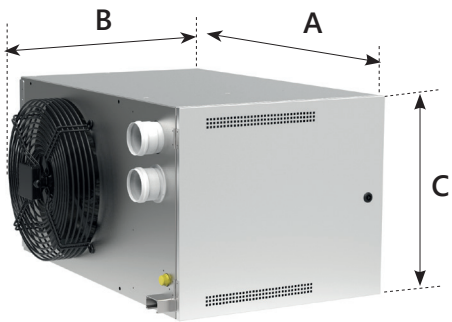

Models	KARU25H	KARU35H	KARU45H	KARU60H	KARU80H
A (mm)	1 060	1 060	1 060	1 060	1 060
B* (mm)	800	800	875	875	875
C (mm)	495	545	600	710	912
Gas (mm)	3/4"	3/4"	3/4"	3/4"	3/4"
Fumes (mm)	80	80	80	80	80
Air (mm)	80	80	80	80	80
Weight (kg)	82	92	115	152	195

* From the front to back side of gas heater

Flue connection

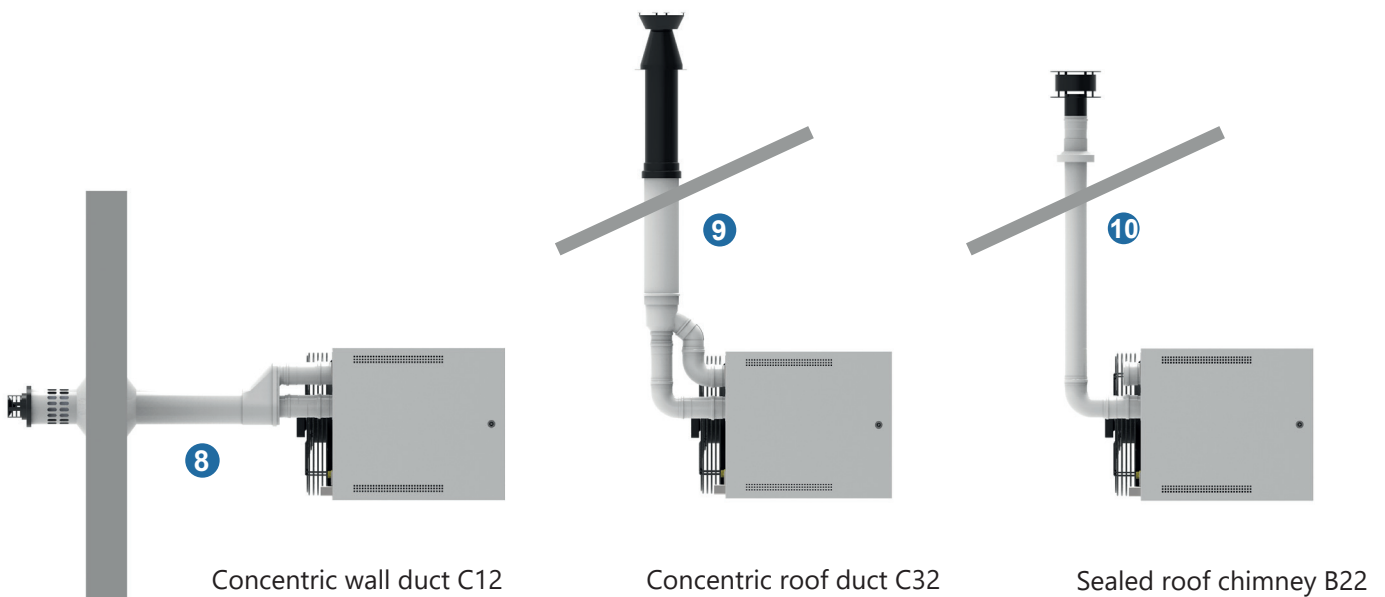

Prices

Models		KARU25H	KARU35H	KARU45H	KARU60H	KARU80H
Axial gas air heater		2 800 € KARU25H	3 100 € KARU35H	3 500 € KARU45H	4 150 € KARU60H	4 950 € KARU80H
Gas connection	Natural gas kit 20 or 25 mBar	1		74 € KGN20		
	Natural gas kit 300 mBar	2		153 € KDGN55		
	Propane gas kit 1,5 Bar	3		168 € KDP55		
	Flexible gas connection	4		79 € FLEXIND3/4		
Fixation	Directional wall-mounted bracket	5		180 € COATX		-
	Wall-mounted bracket	6		200 € CORATX		-
	Vertical bracket	7		140 € COVATX		-
	KRSJ kit for directional bracket			74 € KIPN		
Grille	Vertical supply air grille	140 € GRATX25V	160 € GRATX35V	180 € GRATX45V	200 € GRATX60V	240 € GRATX80V
	Flue pipes	Concentric wall duct C12	8		185 € KC1280ATX	
Concentric roof duct C32		9		295 € KC3280ATX		
Sealed roof chimney B22		10		Consult us		
Single extension 1 m				44 € LE80100		
Single extension 0,5 m				35 € LE80050		
Single elbow 45°				27 € CE8045		
Single elbow 90°				29 € CE8090		
Concentric extension 1 m				118 € LC80100		
Concentric extension 0,5 m				96 € LC80050		
Concentric elbow 45°				99 € CC8045		
Concentric elbow 90°			96 € CC8090			
Regulation	Switch disconnecter	11		69 € BSAT4P		
	Thermostat + remote reset	12		106 € TFP1-ET85P2		
	Timer thermostat + remote reset	13		347 € TFP2TS (FRANCAIS) TFP2TSE (ENGLISH)		
	Timer thermostat with external sensor + remote reset			401 € TFP3TS (FRANCAIS) TFP3TSE (ENGLISH)		

